

# Control and Stability of Large-scale Power System with Highly Distributed Renewable Energy Generation: Viewpoints from Six Aspects

Qing-Hua Wu, *Life Fellow, IEEE, Fellow, CSEE*, Anjan Bose, *Life Fellow, IEEE*, Chanan Singh, *Life Fellow, IEEE*, Joe H. Chow, *Life Fellow, IEEE*, Gang Mu, *Fellow, CSEE*, Yuanzhang Sun, *Senior Member, IEEE*, Zhaoxi Liu, *Senior Member, IEEE*, Zhigang Li, *Senior Member, IEEE*, and Yang Liu, *Member, IEEE*

**Abstract**—Power systems are moving toward a low-carbon or carbon-neutral future where high penetration of renewables is expected. With conventional fossil-fueled synchronous generators in the transmission network being replaced by renewable energy generation which is highly distributed across the entire grid, new challenges are emerging to the control and stability of large-scale power systems. New analysis and control methods are needed for power systems to cope with the ongoing transformation. In the CSEE JPES forum, six leading experts were invited to deliver keynote speeches, and the participating researchers and professionals had extensive exchanges and discussions on the control and stability of power systems. Specifically, potential changes and challenges of power systems with high penetration of renewable energy generation were introduced and explained, and advanced control methods were proposed and analyzed for the transient stability enhancement of power grids.

**Index Terms**—Distributed energy resources, high converter penetration, power system control, renewable energy generation, stability control, transient stability.

## I. PROFESSOR ANJAN BOSE: GRID CONTROL CHALLENGES: RELIABILITY AND RESILIENCY

**T**HE power grid architecture is undergoing a substantial transformation with the current efforts to phase out

Manuscript received December 13, 2022; revised January 1, 2023; accepted January 12, 2023. Date of online publication January 25, 2023; date of current version January 30, 2023. The insights presented in this article are drawn from “CSEE JPES forum on control and stability of large-scale power system with highly distributed renewable energy generation”, organized by Professor Xiaoxin Zhou.

Q. H. Wu is with the School of Electric Power Engineering, South China University of Technology, Guangzhou 510640, China.

A. Bose is with the School of Electrical Engineering & Computer Science, Washington State University, Pullman, WA 99164, USA.

C. Singh is with the Department of Electrical and Computer Engineering, Texas A&M University, College Station, TX 77843, USA.

J. H. Chow is with the Department of Electrical, Computer and Systems Engineering, Rensselaer Polytechnic Institute (RPI), Troy, NY, USA.

G. Mu is with the Key Laboratory of Modern Power System Simulation and Control & Renewable Energy Technology, Ministry of Education (Northeast Electric Power University), Jilin 132012, China.

Y. Z. Sun is with the School of Electrical Engineering and Automation, Wuhan University, Wuhan 430072, China.

Z. X. Liu (corresponding author, email: liuzhaoxi@scut.edu.cn), Z. G. Li, and Y. Liu are with the School of Electric Power Engineering, South China University of Technology, Guangzhou 510640, China.

DOI: 10.17775/CSEEJPES.2022.08740

the generators that produce greenhouse gases and replace them with renewable energy. Against this background, two major changes that are happening in power systems were highlighted in the presentation. First, the large generators on the transmission system are being replaced by many more small generators that are distributed over both the transmission and distribution systems. The second important change is that some new abilities on the distribution feeders become available because more variables are measured, and more controllable devices and resources are deployed on the distribution feeders. Then three areas in power system control that face new challenges were listed. The first area is automatic control, including automatic generation control (AGC) and automatic voltage control (AVC), which are automatically performed by the control center. The second area is the manual control that sets the generation reserves and voltage set-points and makes topology changes. The third area covers the protection schemes in which the special protection schemes and distribution protection that are increasingly relevant to the control of the whole grid were emphasized in the presentation. Given the background above, the major technical challenges in each area were presented. For AGC and voltage control, the distribution level generation and other resources on the distribution side should be visible and controllable to the energy management system (EMS), which is not currently being measured. For manual control, a considerable share of the generation reserves comes from the distribution side, which is currently invisible to transmission level operators. Similarly, the voltage set points must be determined on both the transmission and distribution sides. Furthermore, the topology reconfiguration has to be coordinated between the transmission and distribution operators, as either operator can only control the switches in the respective grid. An obvious challenge for protection and fast control is that protection schemes should be designed and calculated differently to cope with new situations, e.g., fault ride-thru and 2-way flow. Then, the added challenge from load growth in both developed and developing countries was discussed. The increase in capacity will require major investment in the generation, transmission and distribution sectors, and operating much larger grids will require more sophisticated communication, computation and control than available today.

Then, new challenges to power system reliability and re-

siliency along with the transformation of the grid architecture were presented. As the bulk power systems and distribution systems will be operated very closely together, the issue that the existing reliability metrics evaluate the two types of systems separately and differently has to be resolved. Following the introduction to the concept of resiliency and its connection with reliability, the requirement for faster recovery by resilient power grids was demonstrated with the example of the Katrina Hurricane, which had caused long power outages in the city of New Orleans in the United States.

## II. PROFESSOR CHANAN SINGH: GRID TRANSITION TOWARDS CARBON-NEUTRAL ELECTRICITY AND MOBILITY

In the United States and many other countries, the electric power and transportation sectors are the two largest contributors to greenhouse gas (GHG) emissions [1]. A giant step toward carbon neutrality can be taken by decarbonizing electricity generation and electrifying a substantial portion of the transportation sector. In the presentation, the important research topics and questions that need to be addressed to facilitate this transition were highlighted. The first topic is the proper algorithmic control protocol that would ensure the physical and cyber security of a large-scale stochastic dynamic system, e.g., estimating a security region by learning a Lyapunov function [2]. The second topic concerns the theory and cost-risk analysis of the reliability performance of a power grid with deepening penetration of intermittent supply and demand. The limits of the existing reliability performance measures that cope with conventional generation and passive demand in the context of the new changes were emphasized and explained [3]. A few game changers that will affect the reliability and resource adequacy issue were listed in the presentation. These game changers include variable energy resources that do not exhibit firming capacity, storage, demand flexibility, distributed energy resources (DERs) at the distribution level, and DERs behind the meter. Then, a few important questions that need to be answered in a carbon-neutral power grid with the new changes were highlighted. The questions include the following:

- Given a large penetration of variable energy resources, can capacity-based resource adequacy planning work?
- What is the meaning of a target loss of load expectation (LOLE) in the presence of demand flexibility?
- How do DERs at the distribution level, participating in demand, change resource adequacy planning?
- How does this customer participation in reliability improvement impact adequacy planning at the independent system operator (ISO) level?
- With DERs at the distribution level and behind the meter, who is responsible for reliability?

The question of what the pricing construct will be for uncertainty and flexibility in carbon-neutral electricity systems was then presented as an important issue in the new environment. The issue of EVs that have both faces as demand and potential capacity providers was emphasized, and the question of how to construct a market for EV storage was

raised. To support these common research interests and efforts, Professor Chanan Singh and Professor Le Xie *et al.* proposed a synthetic system with open-source data for the climate-concerned research community [4]. In the summary, it was presented that the electric grid and electrification would play a crucial role in carbon neutral transition. A whole set of open questions regarding reliability, markets and architecture remain to be addressed for grid transformation. All these works open an exciting era for next-generation power grid leaders to make a global impact on the energy and climate community.

## III. PROFESSOR JOE H. CHOW: ENABLING INVERTER-BASED RESOURCE STABILITY CONTROL IN POWER SYSTEMS WITH HIGH CONVERTER PENETRATION

In the opening remarks, the challenges in the future grid with high penetration of inverter-based resources that converters need to overcome low inertias and weak grid issues were highlighted, and the great potential of inverters in providing fast active and reactive power control for enhancing the power system stability was revealed by the presenter. A few important functions in power system operations can move to a faster time scale with renewables interfaced by inverters, as shown in Fig. 1 [5]. The presentation focused on three research topics. First, to enhance the transient stability, an adaptive dynamic power reduction (aDPR) scheme was proposed for type-3 wind turbine generators (WTGs) [6]. The main idea of the proposed aDPR scheme is to reduce the WTG active power output during the fault and ramp it back gradually to full power so that it acts like a braking resistor. Second, the idea of utilizing WTGs to perform frequency control was explained. It was pointed out in the presentation that it is important to create a headroom, and the frequency control must be responsive and fast for the idea of WTG frequency control. An active power control scheme was proposed for frequency control, which requires the WTG to pitch back the wind turbine blades to spill power and create a headroom [7]. An example of frequency regulation using WTGs with data from ERCOT (System Operator of Texas, the United States) was then shown in the presentation. It was demonstrated that the idea of WTG

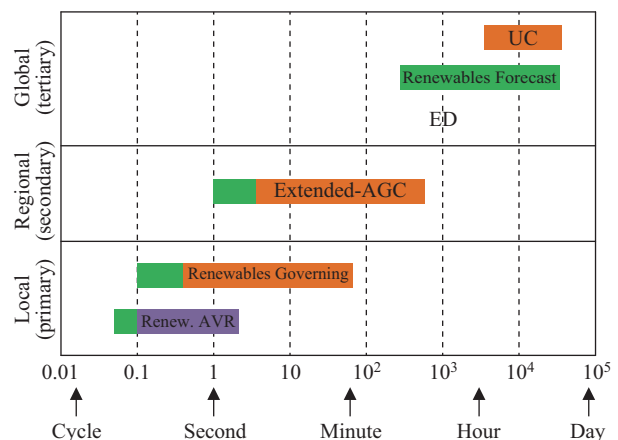

Fig. 1. Time scale diagram of hierarchical control of a power system with high penetration of renewable energy resources [5]. The unit of the numbers on the horizontal axis is second.

frequency control is highly feasible. Third, an analysis on disturbance propagation in a power grid with high converter penetration was presented [8]. The analysis was performed by replacing the conventional synchronous generators in a radial power system with renewable resources interfaced by inverters. The results show that the inverter penetration proportion has an impact on the propagation speed, which suggests that the protection systems that are set based on the travel speed should take such impacts into consideration. Meanwhile, the findings that grid-forming inverters in virtual synchronous generator (VSG) mode will slow down the propagation speed and that proper inverter power control can stop the disturbance propagation were also presented. In the conclusion, it was noted that although mostly viewed as a black box, an inverter is very capable, yet its capability is not fully utilized. Inverters can provide fast active power control and potential benefits to many stability situations for AC power systems if their MVA rating is slightly oversized with respect to the MW rating.

#### IV. PROFESSOR GANG MU: CHALLENGES OF STABILITY STUDIES FOR THE POWER SYSTEMS WITH HIGH PENETRATION OF RENEWABLE ENERGY SOURCES

In the presentation, the definitions of power system stability and their historical evolution since the 1920 s were first briefly reviewed [9]–[14]. It was highlighted that many stability-related key factors will be changed due to the large-scale deployment of converters with high penetration of renewable energy sources (HPREs) in future power systems, as listed in Fig. 2. The changes in dynamic modeling conditions of the power systems with HPREs were presented, and two important changes were emphasized: 1) the time scales of the electromagnetic and electromechanical processes would be mixed, and their dynamics are hard to decouple; 2) the linearized models are no longer valid for stability analysis in some emerging nonlinear problems. The different dynamic characteristics of traditional power systems and future power systems with HPREs were demonstrated through two simple examples with the wind farm (WF) convertor and synchronous machine (SM) in a synthetic system with 3-phase short circuit faults. The simulation results of the two examples show that compared with the SM, the WF convertor has a small stable domain, is insensitive to the operating point and is monotonically dependent on the short circuit capacity. Then, three challenges to the stability study of power systems by

HPREs were highlighted, including the challenges from the huge number of converters, weak tolerance of converters, and high computational cost of electromagnetic simulations. Regarding the modeling of wind turbine generators for power system stability studies, the presenter and the other authors of [15] provided a comprehensive overview of wind turbine generator modeling for various stability studies in the review, and a conceptual modeling framework was established to address how to obtain an appropriate model for specific types of stability studies. Then, the question of how to address the challenges of stability studies with HPREs was discussed from three perspectives, including theory, method and computation. On the theory part, two research topics were suggested, including creating a general stability theory for power systems with HPREs and soundly revealing the interaction mechanism of all elements in power grids. On the method part, various analysis methods were encouraged, including the model-based, data-based and other new methods. On the computation part, research was suggested on the criterion to verify the model validity of power systems with HPREs, the valid limitation of the linearized model for stability assessment of power systems with HPREs, and how to improve the modeling of WF and PV cluster calculation to fit the stability analysis with HPREs for which functional modeling was mentioned as a possible solution.

#### V. PROFESSOR YUANZHANG SUN: CONTROL METHOD OF THE LOAD DAMPING FACTOR FOR PRIMARY FREQUENCY REGULATION OF POWER SYSTEMS WITH HIGH-PROPORTION RENEWABLE GENERATION

Electric loads have been studied for a long time, and relevant research topics include but are not limited to load modeling, emergency load shedding, underfrequency load shedding, frequency control and peak regulation. Past experience and current studies have shown that a huge amount of loads of different consumers can serve as important controllable and dispatchable resources for future power grids. To clarify the background and motivation of the presented work, the emerging challenge of insufficient primary frequency regulation (PFR) capability of power grids in the near future was discussed, which had been indicated by the results of field tests in the central China power system and the power system of Yunnan Province, China. It was also noted that the risk of insufficient PFR capability can be more serious in the

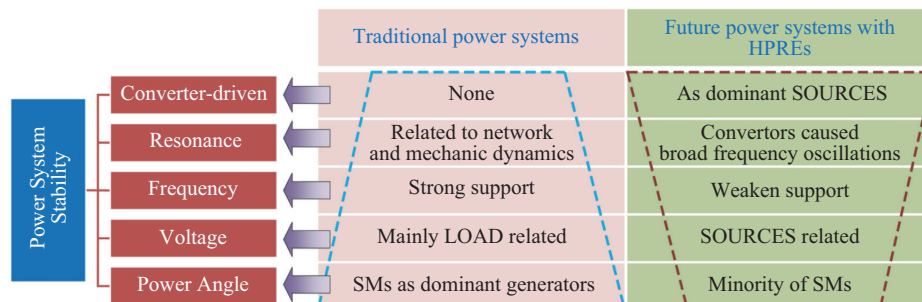

Fig. 2. A list of power system stability-related key factors.

future as many coal-fueled generation units may be replaced by renewables. After a brief review of the concept, advantages and existing control technologies of electric loads participating in PFR, the fact that voltage-sensitive loads account for a large proportion of composite loads in PFR applications was highlighted. Then, a critical research question was raised: how can a huge amount of voltage-sensitive loads that are widely distributed in low-voltage feeders be used for the PFR? To address this problem, a systematic method was proposed by the presenter and his team to flexibly aggregate and control voltage-sensitive loads. First, the detailed definition of the composite load was introduced, and the idea of the proposed frequency feedback controller was presented. The proposed controller introduces the frequency feedback to control the bus voltage of the composite loads, such that the response of the active power of the loads to the frequency of the grid can be changed from the natural response to the controlled response. The proposed feedback control can be connected to the static Var generator (SVG), as demonstrated by the example shown in Fig. 3. The shown controller was named load damping controller, which can achieve the proposed controlled response because the voltage-sensitive part of the composite loads will positively respond to the system frequency deviation. Then, the theoretical analysis results on the impacts of the controlled response with the introduced load damping controller on the PFR were provided, and the tuning method of the gain for the proposed controller according to the allowable amount of voltage adjustment was explained. Finally, a quantitative analysis on the effects of the proposed load damping control on PFR enhancement was presented. The results show that the proposed load damping control can improve the PFR capability of the grid, and the potential of load control is very important in future power grids with high penetration of renewable energy generation.

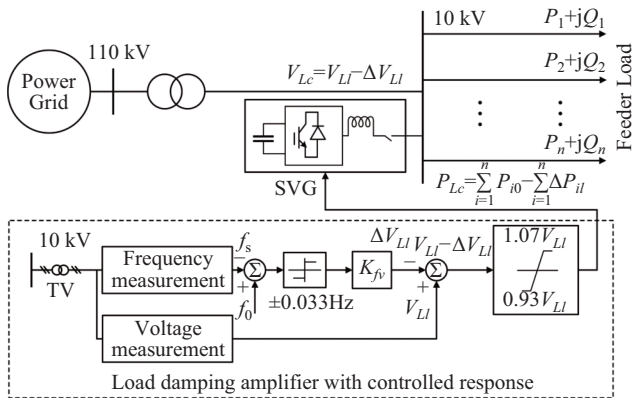

Fig. 3. Structure of the frequency feedback controller.

## VI. PROFESSOR QING-HUA WU: TRANSIENT STABILITY ENHANCEMENT OF LARGE-SCALE POWER SYSTEMS USING MAXIMUM ENERGY BALANCE CONTROL

The transient stability of large-scale power systems is threatened by events such as natural disasters, system failures and violations of operation limits with high impact and low possibility (HILP). The increase in renewable power generation will

make the problem even more serious. Against this background, the risks of shortages of energy balance control strategies and coordinated control frameworks in the future were spotlighted in the presentation. The issues of the conventional stability control framework, which are preconfigured and whose parameters are set from simulation results, were explained. Given the challenges and problems of the control and analysis methods for the transient stability of power systems, there is a strong need for solutions that do not need accurate models, can achieve coordinated control for distributed controllers, be able to provide maximum transient energy for transient stability, be able to estimate nonlinearities and uncertainties through dynamic mode observations. Due to factors including uncertainties in the model structure and parameters, measurement infeasibility and unknown dynamics, control that requires an accurate model and perfect information may not be possible in practice. Different from conventional model-based adaptive control, a nonlinear adaptive control method was proposed by the presenter, in which state and perturbation estimation can be achieved and only a very small number of outputs are needed as system feedback [16]. The proposed nonlinear adaptive control does not require an accurate system model. Specifically, a fictitious state is introduced to modify the system model to include all the nonlinear dynamics in the proposed control scheme. By feeding one system output to a nonlinear observer, the state and nonlinear dynamics can be estimated and identified. The proposed nonlinear adaptive control method was applied for wind turbine generators [17], [18]. In these applications, only four variables are taken as feedback, while all the functions required by the wind turbine control are achieved by the proposed control method. The proposed control method was also applied for the control of servo motors with large inertia and high nonlinearity. The results of the application show that both the variables and disturbance can be identified by the proposed control method with high accuracy. Then, the maximum energy balance control based on the bang-bang funnel control method was presented. The control method was applied for wind turbine power control, and the results show significant control performance improvement with the proposed control method. Finally, a distributed maximum energy balance control framework for power systems was proposed, as shown in Fig. 4. Simulation

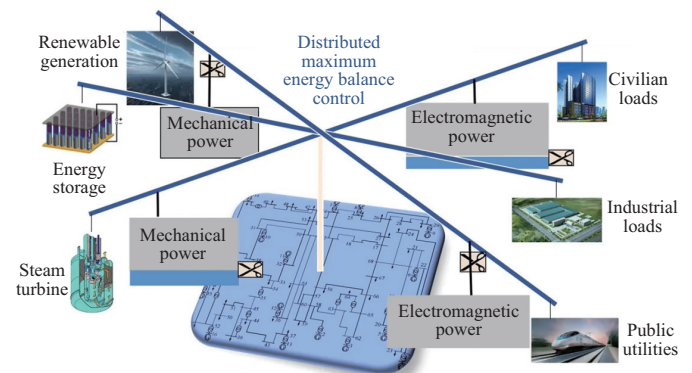

Fig. 4. Framework of the distributed maximum energy balance control.

results show that the damping and transient stability of the grid after faults can be greatly improved by the proposed control framework [19]. In summary, the proposed nonlinear adaptive control based on state and perturbation observers does not need accurate system models, requires only measurements of output variables, and does not ignore any system nonlinearity, parameter uncertainty and external disturbances. The proposed maximum energy balancing control accelerates the rebalancing of power generation and consumption during the postfault stage and greatly enhances the transient stability of power systems. It was also emphasized that more devices of maximum energy balance control, particularly energy storage devices, should be developed, and a new generation of distributed stability control framework is expected.

## VII. CONCLUSION

In this article, opinions on the control and stability of large-scale power systems with high penetration of renewable energy generation were presented. Analysis and control methods were proposed to reveal and meet the challenges to power systems posed by the increasing renewable energy generation that is highly distributed across the entire grid. Specifically, Professor Anjan Bose introduced the changes and challenges of power systems due to the increasing penetration of renewable energy generation in power grids. Professor Chanan Singh presented the critical research challenges for the decarbonization of electricity generation and electrification of the transportation sector. Professor Joe H. Chow proposed the fast active power control methods of inverters for system transient stability enhancement and mitigation of disturbance propagation. Professor Gang Mu analyzed the challenges to power system stability from the replacement of synchronous machines by renewable generation, and important research topics were suggested. Professor Yuanzhang Sun proposed the load damping control method to enhance the primary frequency regulation capability of the grid with high penetration of renewables. Professor Qing-Hua Wu proposed the distributed maximum energy balance control framework based on nonlinear adaptive control and the bang-bang funnel control method for the transient stability enhancement of large-scale power systems. The invited experts elaborated their experience and viewpoints on the control and stability of power systems with high penetration of renewable energy generation. The major viewpoints of the experts are summarized as follows.

1) Higher coordination between the transmission and distribution systems and higher automation of the power system control will be needed in power systems with highly distributed renewable energy generation.

2) New reliability theory and evaluation methodologies of power systems should be developed to cope with demand flexibility and highly distributed renewable energy generation across transmission and distribution networks.

3) Power electronic interfaces of renewable energy generation have great potential in providing fast active power control to enhance the power system transient stability. It is highly beneficial to create headroom for inverters during the planning process.

4) For power systems with high renewable energy generation, the operation characteristics would be profoundly changed. Many operating challenges, including some stability problems, need to be addressed for power systems.

5) Load damping control has great potential in enhancing the primary frequency regulation capability of power systems, which is increasingly needed for future low-carbon or carbon-neutral scenarios.

6) New energy balance control strategies and coordinated control frameworks should be developed for future power systems against the threats to transient stability. A new generation of distributed stability control frameworks is expected. The maximum energy balance control framework based on nonlinear adaptive control and the bang-bang funnel control method provides a distributed control method to enhance the transient stability of large-scale power systems, which does not require accurate system models or ignore any system nonlinearity, parameter uncertainty and external disturbances.

## REFERENCES

- [1] L. Xie, C. Singh, S. K. Mitter, M. A. Dahleh, and S. S. Oren, "Toward carbon-neutral electricity and mobility: Is the grid infrastructure ready?," *Joule*, vol. 5, no. 8, pp. 1908–1913, Aug. 2021.
- [2] T. Huang, S. C. Gao, X. Long, and L. Xie, "A neural lyapunov approach to transient stability assessment in interconnected microgrids," in *Proceedings of the 54th Hawaii International Conference on System Sciences*, 2021, pp. 3330–3339.
- [3] C. Singh, P. Jirutitijaroen, and J. Mitra, *Electric Power Grid Reliability Evaluation: Models and Methods*, Hoboken, New Jersey: John Wiley & Sons, Inc., 2018.
- [4] D. Q. Wu, X. T. Zheng, Y. X. Xu, D. Olsen, B. N. Xia, C. Singh, and L. Xie, "An open-source extendable model and corrective measure assessment of the 2021 Texas power outage," *Advances in Applied Energy*, vol. 4, pp. 100056, Nov. 2021.
- [5] D. Osipov and J. H. Chow, "Operation paradigm for power systems with high penetration of renewables and effects of climate change," presented at the *2021 IEEE Power & Energy Society General Meeting (PESGM)*, 2021, pp. 1–4.
- [6] S. Konstantinopoulos and J. H. Chow, "Active power control of DFIG wind turbines for transient stability enhancement," *IEEE Open Access Journal of Power and Energy*, to be published.
- [7] F. Wilches-Bernal, J. H. Chow, and J. J. Sanchez-Gasca, "A fundamental study of applying wind turbines for power system frequency control," *IEEE Transactions on Power Systems*, vol. 31, no. 2, pp. 1496–1505, Mar. 2016.
- [8] H. T. Cui, S. Konstantinopoulos, D. Osipov, J. N. Wang, F. X. Li, K. L. Tomsovic, and J. H. Chow, "Disturbance propagation in power grids with high converter penetration," *Proceedings of the IEEE*, to be published.
- [9] C. P. Steinmetz, "Power control and stability of electric generating stations," *Transactions of the American Institute of Electrical Engineers*, vol. XXXIX, no. 2, pp. 1215–1287, Jul. 1920.
- [10] C. Barbier and L. Carpentier, "Tentative classification and terminologies relating to stability problems of power systems," *ELECTRA* (56), 1978.
- [11] IEEE Task Force Report, "Proposed terms & definitions for power system stability," *IEEE Transactions on Power Apparatus and Systems*, vol. PAS-101, no. 7, pp. 1894–1898, Jul. 1982.
- [12] P. Kundur, *Power System Stability and Control*, New York, NY, USA: McGraw-Hill, 1994.
- [13] P. Kundur, J. Paserba, V. Ajjarapu, G. Andersson, A. Bose, C. Canizares, N. Hatziaargyriou, D. Hill, A. Stankovic, C. Taylor, T. Van Cutsem, and V. Vittal, "Definition and classification of power system stability," *IEEE Transactions on Power Systems*, vol. 19, no. 3, pp. 1387–1401, Aug. 2004.
- [14] IEEE PES Power System Dynamic Performance Committee, "Stability definitions and characterization of dynamic behavior in systems with high penetration of power electronic interfaced technologies," *IEEE Power & Energy Soc.*, Piscataway, NJ, USA, Rep. PES-TR77, 2020.



- [15] X. Q. He, H. Geng, and G. Mu, "Modeling of wind turbine generators for power system stability studies: A review," *Renewable and Sustainable Energy Reviews*, vol. 143, pp. 110865, Jun. 2021.
- [16] L. Jiang and Q. H. Wu, "Nonlinear adaptive control via sliding-mode state and perturbation observer," *IEE Proceedings - Control Theory and Applications*, vol. 149, no. 4, pp. 269–277, Jul. 2002.
- [17] Y. Liu, Q. H. Wu, X. X. Zhou, and L. Jiang, "Perturbation observer based multiloop control for the DFIG-WT in multimachine power system," *IEEE Transactions on Power Systems*, vol. 29, no. 6, pp. 2905–2915, Nov. 2014.
- [18] X. Lin, K. S. Xiahou, Y. Liu, and Q. H. Wu, "Design and hardware-in-the-loop experiment of multiloop adaptive control for DFIG-WT," *IEEE Transactions on Industrial Electronics*, vol. 65, no. 9, pp. 7049–7059, Sep. 2018.
- [19] Y. Liu, Q. H. Wu, and X. X. Zhou, "Coordinated switching controllers for transient stability of multi-machine power systems," *IEEE Transactions on Power Systems*, vol. 31, no. 5, pp. 3937–3949, Sep. 2016.



**Qing-Hua Wu** received an M.Sc. degree in Electrical Engineering from Huazhong University of Science and Technology, Wuhan, China, in 1981, and a Ph.D. degree in Electrical Engineering from the Queen's University of Belfast (QUB), Belfast, U.K., in 1987. He is currently a Distinguished Professor and the Director of Energy Research Institute, South China University of Technology, Guangzhou, China. He worked as the Chair Professor at Liverpool University from 1995 to 2012. He is a Life Fellow of IEEE, Fellow of IET, CSEE Fellow, Fellow of

AAIA, and Chartered Engineer. He has authored and coauthored more than 350 journal papers, 20 book chapters and 4 research monographs published by Springer Nature. His research interests include nonlinear adaptive control, mathematical morphology, artificial intelligence, and power system control and operation.



**Anjan Bose** is a Regents Professor and the Distinguished Professor of Electric Power Engineering at Washington State University, where he also served as the Dean of the College of Engineering & Architecture from 1998 to 2005. He served the US Department of Energy as a Senior Advisor on the electric power grid in the Obama administration. He is a Member of the US National Academy of Engineering (NAE), a Foreign Member of both the Indian National Academy of Engineering (INAE) and the Chinese Academy of Engineering (CAE),

a Life Fellow of IEEE, and a Foreign Fellow of CSEE.



**Chanan Singh** is a University Distinguished Professor in Electrical and Computer Engineering at Texas A&M. He is a Member of the US National Academy of Engineering, a Foreign Fellow of the Indian National Academy of Engineering, and a Foreign Fellow of Chinese Society for Electrical Engineering. He is a Life Fellow of IEEE. He received the inaugural IEEE-PES Roy Billinton Power System Reliability Award. He received the 1998 Outstanding Power Engineering Educator Award given by the IEEE Power Engineering Society and Lifetime

Achievement Award from IEEE-PES.



**Joe H. Chow** received the M.S. and Ph.D. degrees from the University of Illinois at Urbana-Champaign, USA. After working in the General Electric Power System Business in Schenectady, NY, USA, he joined Rensselaer Polytechnic Institute, Troy, NY, USA, in 1987, where he is Institute Professor of Electrical, Computer, and Systems Engineering. His research interests include power system dynamics and control and synchronized phasor measurement. He is a Life Fellow of IEEE, a Foreign Fellow of CSEE, and a Member of the US National Academy of Engineering. He was a past recipient of the IEEE PES Charles Concordia Power Engineering Award and Outstanding Power Engineering Educator Award.



**Gang Mu** received the Ph.D. degree in Electrical Engineering from Tsinghua University, China. He is currently a First Class Professor at the Northeast Electric Power University, China. He is a Fellow of CSEE, Fellow of IET and deputy editor-in-chief of the Proceedings of the CSEE. His research interests include power system stability analysis; planning and the operation analysis of power systems with HPRES; big data/AI applications in power systems; and application of energy storage in power systems.



**Yuanzhang Sun** received the B.S. degree from the Wuhan University, the M.S. degree from the Electric Power Research Institute (EPRI), and the Ph.D. degree from Tsinghua University, all in Electrical Engineering. He is currently a Professor of the School of Electrical Engineering and Automation with Wuhan University, and a Chair Professor of the Department of Electrical Engineering. He was approved the Distinguished Young Scientist Fund by NSFC in 1998 and was a Distinguished Professor of Cheung Kong Scholars Programme from 2000 to

2005. He is a Senior Member of IEEE. His main research interests include power system dynamics and control, wind power, voltage stability and load control.

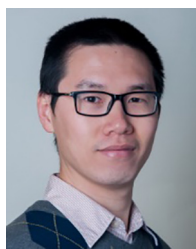

**Zhaoxi Liu** received the Bachelor and Master degrees from Tsinghua University and the Ph.D. degree from Technical University of Denmark. He joined the School of Electric Power Engineering, South China University of Technology since 2022 after four years with the University of Wisconsin-Milwaukee, WI, USA. He was a visiting scholar with the University of California, Berkeley, CA, USA in 2014. His research interests include power system operation and control, power system security and risk management, and the integration of renewable

energy sources and distributed energy resources in energy systems.



**Zhigang Li** received the Ph.D. degree in Electrical Engineering from Tsinghua University, Beijing, China, in 2016. He is currently an Associate Professor with the School of Electric Power Engineering, South China University of Technology, Guangzhou, China. He was a Visiting Scholar with the Illinois Institute of Technology, Chicago, IL, USA, and Argonne National Laboratory, Argonne, IL, USA. He is a Senior Member of IEEE, and a Senior Member of CSEE. He serves as an Associate Editor for the IEEE Transactions on Sustainable Energy, and the CSEE

Journal of Power and Energy Systems. His research interests include smart grid operation and control, integrated energy systems, optimization theory and its application in energy systems.



**Yang Liu** received the B.E. and Ph.D degrees in Electrical Engineering from South China University of Technology (SCUT), Guangzhou, China, in 2012 and 2017, respectively. He is currently an Associate Professor in the School of Electric Power Engineering, SCUT. His research interests include the areas of power system stability analysis and control, control of wind power generation systems, and nonlinear control theory.